



Ovator S-600: Design, engineering and technology

Paul Neville

Naim Audio
Southampton Road, Salisbury SP1 2LN, ENGLAND

Introduction

High-end hi-fi speaker design is a multidisciplinary endeavour embracing elements of acoustics, mechanics, materials, vibration, electronics and musical psychology. And thanks both to the extraordinary discrimination of our ears, and our hard-wired sensitivity to ideas and emotions expressed through music, success in speaker design requires that the elements of each discipline be thoroughly optimised. A successful high-end speaker is truly more than the sum of its parts. So the story of the Ovator S-600 is not simply that of a new drive unit technology, it is one of the optimisation of a multitude of interdependent elements where even the apparently mundane can have an influential role to play.

The Ovator S-600 builds on proven Naim speaker design techniques while simultaneously introducing new technologies, new ideas and new refinements; all incorporated in a scheme that offers a striking yet subtle aesthetic and provides great ease of installation.



Fig. 1 Plinth and Floor Spikes

The Ovator S-600 Plinth, Cabinet and Driver Chassis

The foundation of the Ovator S-600 is its plinth. An extremely rigid high pressure aluminium die-casting, the plinth provides location for the cabinet, floor spike fittings, and mounting points for the passive crossover module (or active loom interface) and terminal panel. The floor spike fittings comprise conventional M8 tapped holes at the front, but at the rear the form of the plinth and the detail design of the spikes enables them to be conveniently adjusted and locked from above. The spikes themselves are manufactured from hardened surgical grade stainless steel.

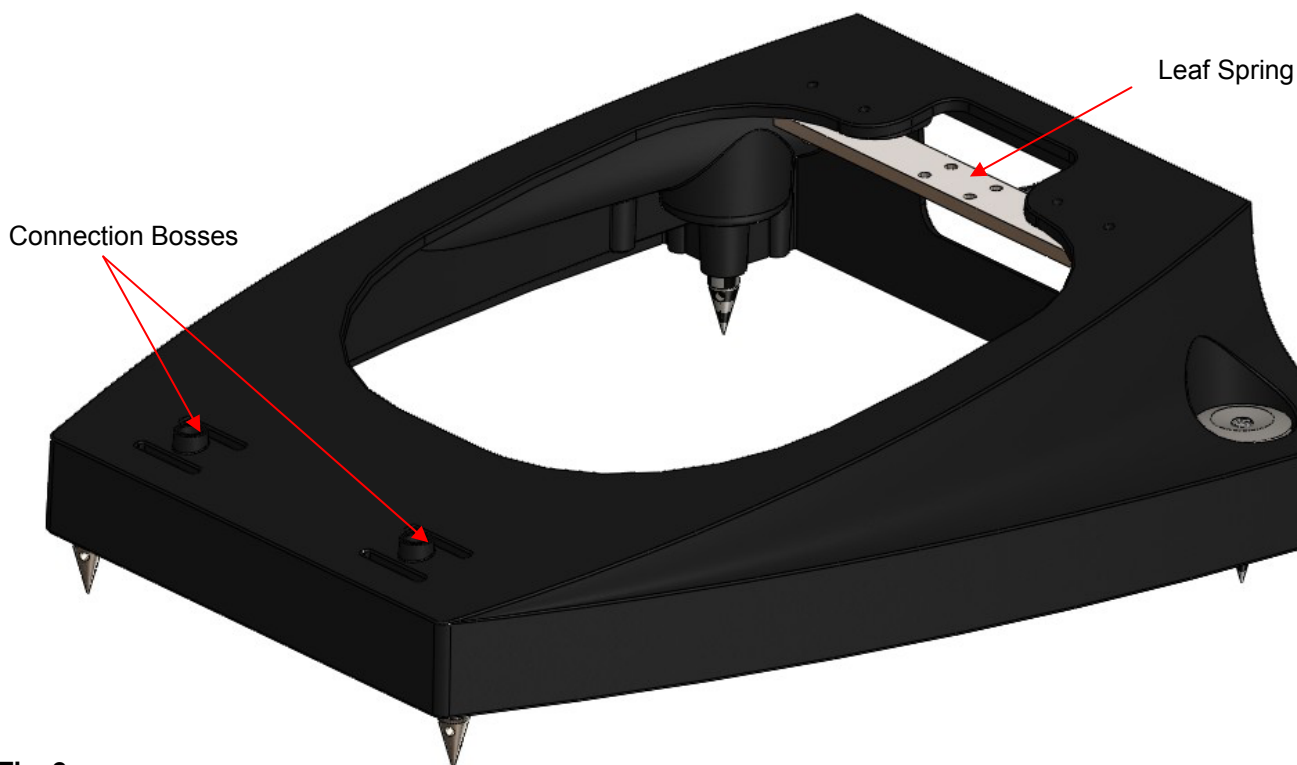

Fig. 2 Plinth Leaf Spring



The Ovator S-600 cabinet is attached to the plinth at two locations towards the front and via a leaf-spring at the rear. The leaf spring is a 200mm stainless steel bar that runs laterally underneath the cabinet and attaches centrally to its underside. At each end the leaf-spring is bolted, via tapped bosses, to the plinth. The front locations comprise stand-off bosses through which a bolt is inserted and screwed into the cabinet. A slot feature either side of each boss introduces some controlled compliance to the front cabinet locations that in combination with the leaf-spring results in the cabinet rotationally (forward and backward) decoupling from the plinth above 12Hz.

The entire plinth and cabinet system was the subject of Finite Element Analysis modelling to analyze, predict and fine-tune its vibration characteristics with the aim of ensuring that any resonant behaviour within the audible band is minimised. Limited decoupling of the system outside the audible band is inherent in achieving this aim. The cabinet/plinth leaf-spring was first introduced on the Naim Allae loudspeaker although the leaf-sprung cabinet concept goes back to the Intro and Credo.



Fig. 4 BMR Sub-assembly

The Ovator S-600 BMR Drive Unit

The Ovator S-600 BMR (Balanced Mode Radiator) has its own separate enclosure formed by a 12.7mm thick aluminium alloy cylinder nested within the cabinet. A unique suspension system comprising two, four element, duralumin circumferential leaf-springs decouples the BMR module from the rest of the cabinet. The suspension system prevents low frequency mechanical energy from the bass drivers interacting with the BMR and stops mid/high frequency mechanical energy being transmitted to the cabinet. The cylinder is held by one leaf-spring at the front of the cabinet and one at the back. The system was Finite Element Analysis modelled and the design optimised to provide a decoupling from 4Hz – more than six octaves below the beginning of the BMR pass-band. The BMR enclosure is gradient filled with a mix of wool felt and reticulated foam and has a vent at the back so that changes in temperature or atmospheric pressure do not impact upon performance. A simple transit system locks-up and protects the suspension system during shipping.



Fig. 3 8" Drive Unit Basket

The Ovator S-600 cabinet is of composite construction with 25mm thick curved sides created from the lamination of (material?) sheets bonded under heat and pressure. This construction effectively incorporates constrained layer damping within the structure of the material to create an immensely rigid and non-resonant panel. The 50mm thick front baffle is created from the lamination of four layers of 12.5mm MDF to create a significantly more rigid and better damped panel than would be achieved through the use of a single sheet. The outside edges of the front baffle are radiused to minimise diffracted radiation and internal bracing and strategic mass damping contribute further to a cabinet that, in acoustic terms, is fundamentally benign. The cabinet is internally lined with 20mm wool felt.

The lower portion of the cabinet is divided into two separate 30 Litre closed box enclosures – one for each bass driver. Closed box loading was chosen thanks to the distinct advantages it offers over other loading techniques in terms of time domain performance and dynamic compression. The Ovator S-600 low frequency system resonance is at 38Hz with a Q of 0.6. The free field -3dB point is 50Hz.

Both the Ovator S-600 bass driver and BMR chassis are custom designed high-pressure die-castings modelled using Finite Element Analysis to optimise their performance by managing the vibration energy that is an unavoidable consequence of their operation. The bass driver chassis for example is characterised by a triangulated structure that not only provides great rigidity but also maximises the open area behind the cone. Additionally It features minimal interface mating surfaces so that mechanical energy transfer to the cabinet is controlled and predictable.

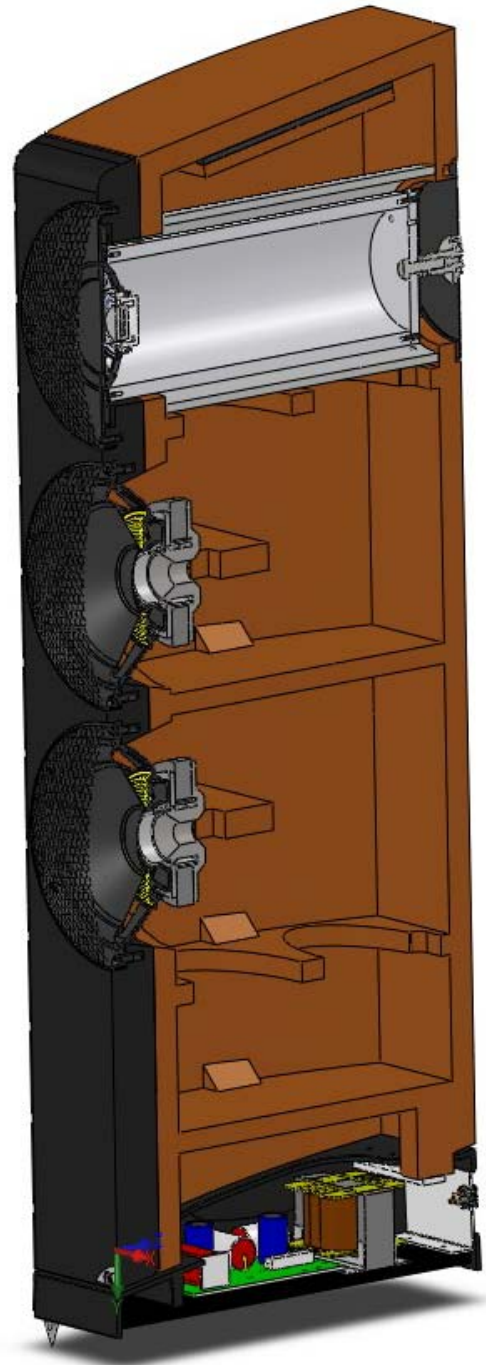

Fig. 5 Speaker Cross-section

The Ovator S-600 Crossover

A significant benefit of the of using a BMR to cover the entire mid and high frequency band is that the typical 2kHz – 3kHz crossover, with its unavoidable phase and dispersion discontinuities, is not required. The Ovator S-600 crossover between bass drivers and BMR operates at 380Hz with fourth order acoustic slopes and minimal phase discontinuity. Thanks to the similarly wide dispersion of the bass drivers and BMR at crossover there is no dispersion discontinuity,

The crossover module itself is attached to the underside of the plinth and comprises a MDF panel carrying a glass-fibre printed circuit board. It is suspended from the plinth via an elastomeric mounting system and selected crossover components also benefit from discrete mechanical decoupling. The topology of the printed circuit board borrows many of the layout and earthing principles of Naim power amplifiers. Components are all of extremely high quality, each selected following extensive technical analysis and listening. Four different types of metalised polypropylene ClarityCap capacitors are used including the new and outstanding ESA type employed as the main BMR feed capacitor. The inductors are a combination of air core and laminate steel core. The LF feed inductor is a huge laminated steel core item of 2.8mH with only 0.08Ω series resistance. The crossover filter and equalisation curves were extensively computer modelled and correlated with measurement and listening. The crossover presents a benign load to driving amplifiers with a minimum impedance of 3.2Ω at 100Hz and a maximum phase shift throughout the entire audible band of ±30°.

For bi-amp or tri-amp active operation the entire crossover can be simply removed and replaced with an active wiring loom adaptor. The terminal panel is also exchanged for one carrying three sets of terminals.

The Ovator S-600 Connectors

The Ovator S-600 features custom designed input terminals that offer a significant advance on conventional items. The conception and design of the terminals was informed by the experience gained from the Naim Hi-Line and Power-Line projects to generate an innovative and high performance speaker connection solution.

The terminal is designed to work optimally with the new Naim solid hardened-copper speaker pin but can also accept standard banana plugs. The sprung contacts optimise contact pressure and minimise contact resistance. They are manufactured from a unique grade of copper alloy with an IACS (International Annealed Copper Standard) of over 90% and enhanced spring properties. The terminal housing is designed to eliminate eddy currents and allow the contacts to float in order to minimise microphonic effects. The complete housing is also designed to float within the aluminium back plate of the speaker.

Bright tin plate on both the contacts and the pins were chosen from listening tests, which confirmed the findings from previous projects. The use of the same plating of both pin and contact minimises the potential for galvanic corrosion and the use of tin/copper conductor combinations has a low thermoelectric coefficient reducing any unwanted currents due to the Seebeck (thermoelectric) effect.

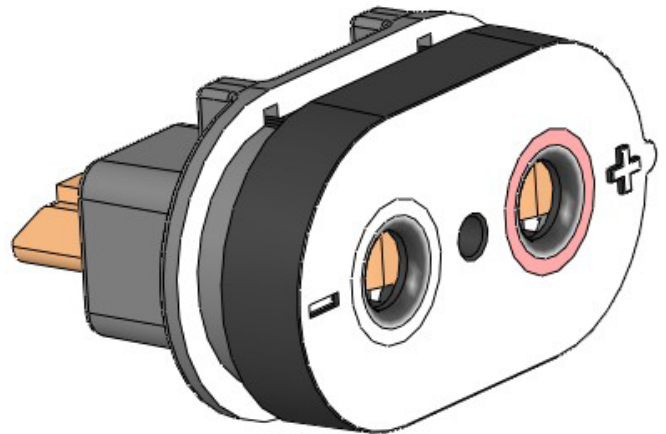

Fig. 6 Speaker Connectors

The Ovator S-600 In Use

Installing and setting-up the Ovator S-600 is simple. It is fitted when packed with a pair of caster trolleys and, with its carton upright and opened at the front, it can simply be wheeled into position. Once in position the caster trolleys can be removed and the Ovator S-600 placed on its pre-fitted floor spikes. Spike adjustment and levelling is simplified enormously by the rear spikes' top adjustment and locking access.

The Ovator S-600 is a wide bandwidth, neutrally balanced and uncoloured speaker capable of very high volume levels without significant compression or distortion. Its exceptional time domain behaviour and extremely low noise-floor mean that fine musical detail is reproduced naturally with coherence and clarity. It is designed primarily for "free-space" positioning within the listening room. However, thanks to its consistent and wide dispersion it is relatively insensitive to positioning. Its listening sweet-spot is also considerably wider than typical conventional speakers.